



Experience since 1998 y.

Manufacturing of
Oil/Water separators;
Grease separators;
Pumping stations;
Waste Water
treatment plants;



Certificates

ISO 9001
ISO 14001
ISO 45001
SINTEF

SINGAPORE GREEN
BUILDING PRODUCT
"VERY GOOD"

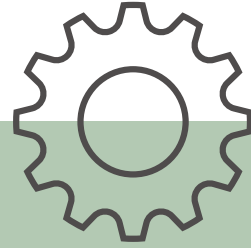

Services

Custom rotational
molding;
Design and
manufacturing of
unique plastic
products;

GEASE SEPARATORS



FREE-STANDING AND UNDERGROUND MODELS



Greasly

Sweden | Finland | Latvia | Norway | Denmark | Belarus | Germany | Russia | India | China | UAE | Kuwait | Saudi Arabia | Singapore



EXPORT COUNTRIES



Sweden | Finland | Latvia | Norway | Denmark | Belarus | Germany | Russia | India | China | UAE | Kuwait | Saudi Arabia | Singapore

UAB Eneka
Vandžiogalos pl. 94D,
LT-47467, Kaunas,
Lithuania

Phone: +370 37 377441
E-mail: info@eneka.lt

www.eneka.lt

GREASLY – a part of the modern kitchen

A typical application of a grease separator is the treatment of wastewater containing fat and grease from hotels, restaurants, cafeterias and other catering or food processing operations. GREASLY will, by the removal of fat and grease, greatly reduce incidents of blocked drains and prevent contamination of sewage treatment plants.

ENEKA offers Free-standing Greasly-A and Underground Greasly-B grease separator models. The body of the separator made of polyethylene material are durable, corrosion-proof and chemically resistant, light and easy to transport.

ENEKA UAB is a Lithuanian company with long-term experience in the manufacturing of oil/water and grease separators. The sales network of ENEKA products covers not only Lithuania and the neighbouring countries as the Baltic states or Scandinavia, but many countries in Europe, the Middle East and Asia as well.

Optimal grease separation

Incoming greasy wastewater enters the grease separator through a unique inlet module which creates the circular flow path. As water passes through the separator, grease particles, lighter than water, are driven upwards by gravity and accumulated in the collection area on the water surface. At the same time, solids and other impurities heavier than water settle to sludge trap at the bottom of the tank. Treated water is discharged through the outlet pipe.



Approvals

Greasly separators were developed to comply with EN1825 and DIN4040-100 standards. Greasly is ensuring the residual grease content less than 25 mg/l in the effluent wastewater. The performance of separators was practically tested (at the Danish Technological Institute and Kaunas University Of Technology). The conformity to European standard EN1825 is signified by the CE mark.



Selection of Nominal Size

According to European Standard EN1825-2 the nominal size shall be determined from the following formula:

$$NS = Q_s \cdot f_t \cdot f_d \cdot f_r$$

where:

NS - the nominal size of the separator.

Q_s - the maximum flow rate in liters per second

f_t - the temperature factor: ($f_t = 1$ if the influent water temperature is ≤ 60 °C; $f_t = 1,3$ if > 60 °C)

f_d - the density factor: $f_d = 1^*$ if density of grease/oil is $\leq 0,94$ g/cm³; $f_d = 1,5$ if $> 0,94$ g/cm³;

(a density factor $f_d = 1$ shall be used for wastewater discharging from kitchens abattoirs, meat and fish processing plants).

f_r - the detergent and rinsing agent factor: $f_r = 1$ detergents never used; $f_r = 1,3$ occasionally or always used; $f_r \geq 1,5$ hospitals and other special cases.

The maximum flow rate Q_s entering the separator shall be calculated from the equation:

$$Q_s = \frac{(F \cdot M \cdot V_m)}{(3600 \cdot t)}$$

where

M - the number of meals per day;

V_m - the volume of water used per meal, in liters (see table 1).

F - the peak flow coefficient (see table 1)

t - the average duration of operation a day, in hours.

| Type of kitchen | V_m , in liters | F |
|--|-------------------|-----|
| Hotel | 100 | 5 |
| Restaurant | 50 | 8,5 |
| Hospital | 20 | 13 |
| Large catering establishment, open all-day | 10 | 22 |
| Factory/Office canteen | 5 | 20 |

For nominal size selection for food processing or any other special applications please consult ENEKA engineers.

Free-standing Grease Separators GREASLY-A

For installation inside buildings

Greasily-A is a new grease separator model made of polyethylene for free-standing installation inside buildings. Greasily-A is compact and lightweight but very rigid units at the same time. All separators are equipped with an integrated sludge trap. Currently, there are nominal sizes of above-ground separators available for flow rates from 2 to 20 l/s.

Fits through any door

A tight grease separator body (width is only 700 mm of NS2 and NS4) can easily fit through any standard door. Thus Greasily-A is a good choice for installation in spaces with narrow access.



Easy selection of flow direction

Due to the symmetrical design of the separator, the flow direction can be selected according to the existing pipeline layout. Inlet or outlet pipe can be connected on the right or left side of the separator.



Disposal Pump

A special heavy-duty disposal pump with vortex impeller (manual and automatic emptying systems of accumulated grease and solids).

Rigid and durable design

The advanced design of the separator's body ensures great stiffness and perfect resistance against internal water pressure and higher temperatures.

Complete emptying of the tank

The bottom of the separator is inclined towards the center. The extraction pipe is connected at the lowest point ensuring complete emptying of accumulated grease and solids from the lowest point.

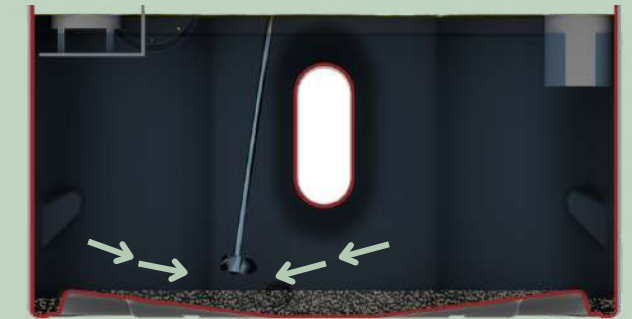

Convenient allocation in the room

The grease separator is maintained from one side only, therefore, it can be set up next to the wall. The accessories (inspection window, extraction pipe, disposal pump) can be attached from both sides.



Inspection window with a wiper for visual control of the grease layer.

No bad odour

Access covers are tightened by a locking ring with a seal ensuring odour-free operation. There is no need to open the cover during the maintenance since accumulated grease and sludge can be disposed of through an extraction pipe or using a disposal pump.

Refilling unit

After disposal, the separator shall be refilled with fresh water without opening the lid and thus ensuring odour-free filling.

Mixer with 2 impellers

Before disposal, accumulated grease and sludge are blended with water to facilitate the emptying of the separator.

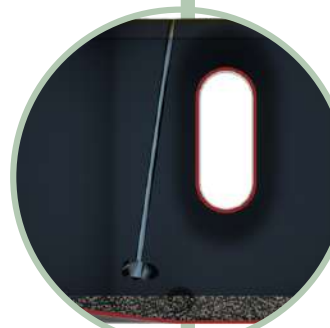

The following main components are included in every Greasly-A model: separator tank with two airtight covers $\varnothing 400$ mm with seals and metallic locking rings, integrated sludge trap, sloped bottom for complete discharge, special inlet and outlet for efficient grease separation.

BASE

BASE model can be applied in areas where bad odour during maintenance will not cause any inconvenience. Access cover shall be opened for disposal of accumulated grease and solids by a vacuum truck.

| NS | Article No. | Weight, kg | Dimensions, mm | | |
|----|-------------|------------|----------------|-----|------|
| | | | L | B | H |
| 2 | 201-0201 | 78 | 1940 | 700 | 1190 |
| 4 | 201-0301 | 91 | 1940 | 700 | 1430 |
| 7 | 201-0401 | 136 | 1776 | 980 | 1750 |
| 10 | 201-0501 | 173 | 2356 | 980 | 1750 |

Greasly-2A Base

MIX

MIX model is equipped with a grease alarm which is indicating when the maximum level of accumulated grease is reached. Before emptying, mixer actuated for blending grease, water and solid layers thus facilitating the disposal of the separator. The extraction pipe is provided for the emptying by the vacuum truck. After complete disposal, the separator is filled up with fresh water via the refilling unit by opening the manual ball valve.

| NS | Article No. | Weight, kg | Dimensions, mm | | |
|----|-------------|------------|----------------|------|------|
| | | | L | B | H |
| 2 | 201-0203 | 119 | 1940 | 842 | 1352 |
| 4 | 201-0303 | 132 | 1940 | 842 | 1590 |
| 7 | 201-0403 | 171 | 1776 | 1080 | 1891 |
| 10 | 201-0503 | 208 | 2356 | 1080 | 1891 |

Greasly-4A Mix

PRIMA

PRIMA model provides odour-free operation without the need for opening of the cover. The accumulated grease layer can be observed through the Inspection window. After reaching the maximum level of grease the contaminants are disposed of through the extraction pipe by a vacuum truck.

After complete disposal, the separator is filled up with fresh water via the refilling unit by opening the manual ball valve.

| NS | Article No. | Weight, kg | Dimensions, mm | | |
|----|-------------|------------|----------------|------|------|
| | | | L | B | H |
| 2 | 201-0202 | 88 | 1940 | 842 | 1286 |
| 4 | 201-0302 | 101 | 1940 | 842 | 1526 |
| 7 | 201-0402 | 145 | 1776 | 1080 | 1816 |
| 10 | 201-0502 | 182 | 2356 | 1080 | 1816 |

Greasly-4A Prima

PUMP-M

After reaching the maximum level of grease the heavy-duty disposal pump is activated. The manual 3-way valve shall be consecutively switched to positions 1 and 2:

Pos.1 - Mixing: water with grease and sludge is extracted by the disposal pump from the bottom and delivered to the top of the separator. The pump with a vortex impeller is breaking the big contaminants into smaller pieces thus facilitating the disposal.

Pos.2 - Disposal: the mixture of water and contaminants is discharged by the disposal pump into the external tank.

After complete disposal, the separator is filled up with fresh water via the refilling unit by opening the manual ball valve.

| NS | Article No. | Weight, kg | Dimensions, mm | | |
|----|-------------|------------|----------------|------|------|
| | | | L | B | H |
| 2 | 201-0204 | 158 | 1940 | 985 | 1286 |
| 4 | 201-0304 | 172 | 1940 | 980 | 1429 |
| 7 | 201-0404 | 267 | 1776 | 1175 | 1816 |
| 10 | 201-0504 | 301 | 2356 | 1175 | 1816 |

Greasly-7A Pump-M

PUMP

PUMP model is equipped with an autonomous program-controlled emptying system including a disposal pump, a mixer and a grease alarm (integrated in the control panel). A grease alarm is indicating when the maximum level of accumulated grease is reached. The operator activates the automatic disposal mode on the control panel or remote controller (optional). First of all, the mixer is turned on for blending grease, water and solids. Then the disposal pump is actuated for emptying of the separator.



Greasly-10A Pump

After complete disposal, the separator can be rinsed by freshwater which is filled through the refilling unit, mixed and emptied by the disposal pump. After rinsing, the separator is filled up completely with fresh water.

| NS | Article No. | Weight, kg | Dimensions, mm | | |
|----|-------------|------------|----------------|------|------|
| | | | L | B | H |
| 2 | 201-0205 | 198 | 1940 | 1060 | 1352 |
| 4 | 201-0305 | 212 | 1940 | 1060 | 1592 |
| 7 | 201-0405 | 277 | 1776 | 1175 | 1891 |
| 10 | 201-0505 | 311 | 2356 | 1175 | 1891 |

Accessories

OPTIONAL:

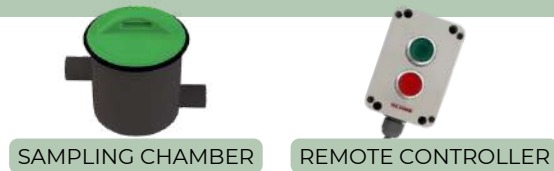

| | Grease Alarm | Extraction Pipe | Refilling Unit | Mixer | Inspection Window | Control Panel | Disposal Pump | Manual 3-way Valve |
|--------|---------------------------------|-----------------|----------------|-------|-------------------|---------------|---------------|--------------------|
| BASE | | | | | | | | |
| PRIMA | | ✓ | ✓ | | ✓ | | | |
| MIX | ✓ | ✓ | ✓ | ✓ | ✓ | ✓ | | |
| PUMP-M | | ✓ | ✓ | | ✓ | ✓ | ✓ | ✓ |
| PUMP | INTEGRATED IN THE CONTROL PANEL | | ✓ | ✓ | ✓ | ✓ | ✓ | |

Greasly 2A - 4A dimensions

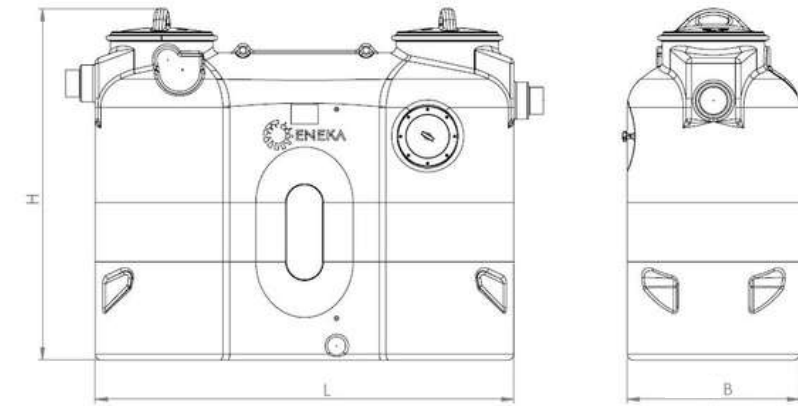

Greasly 7A - 10A dimensions

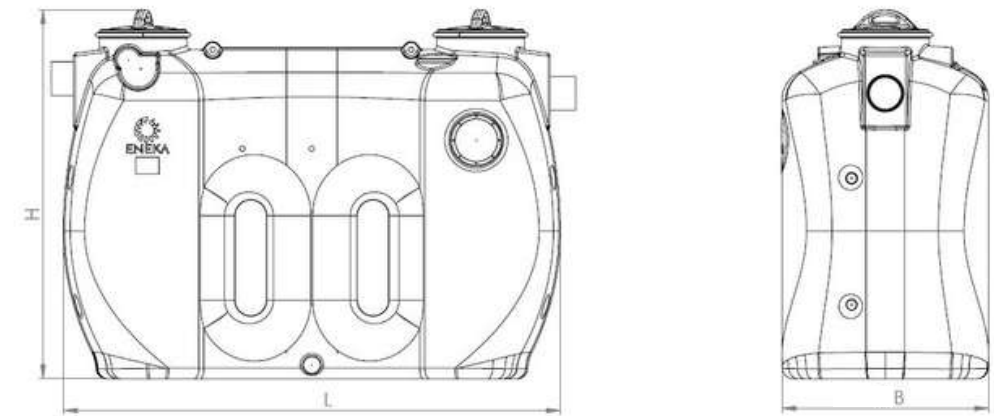

Greasly 15A dimensions

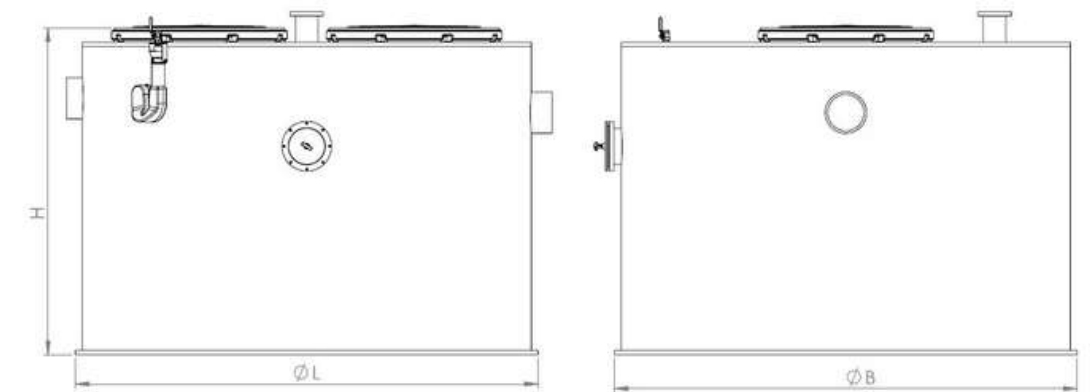

| Type | Flor rate, l/s | Sludge trap volume, l | Separator volume, l | Grease volume, l | Total volume, l |
|-------------|----------------|-----------------------|---------------------|------------------|-----------------|
| Greasly-2A | 2 | 200 | 250 | 80 | 650 |
| Greasly-4A | 4 | 400 | 450 | 160 | 850 |
| Greasly-7A | 7 | 700 | 960 | 280 | 1660 |
| Greasly-10A | 10 | 1000 | 1076 | 400 | 2076 |
| Greasly-15A | 15 | 1500 | 1800 | 600 | 3300 |

Underground Grease Separators GREASLY-B

Rigid body

A great stiffness of the separator body against ground and groundwater loads is achieved due to the advanced design and special ribbed structure. The consistent quality of the product is ensured by the automatic manufacturing method. Due to the seamless structure, the separator is leak and corrosion-proof.

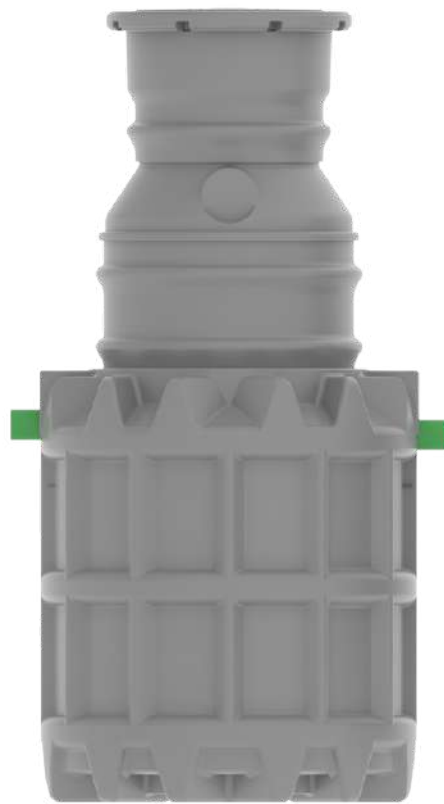

Telescopic maintenance shaft for adjustment of the lid flush with the terrain (adjustment range 200 mm). The manhole shaft is equipped with two special seals. The first seal is located between the tank body and the manhole shaft, the second seal is between the manhole and telescope. The seals ensure that no liquid droplet will penetrate to/from the tank.

The integrated ladder in the maintenance shaft provides easy and safe access to the tank.

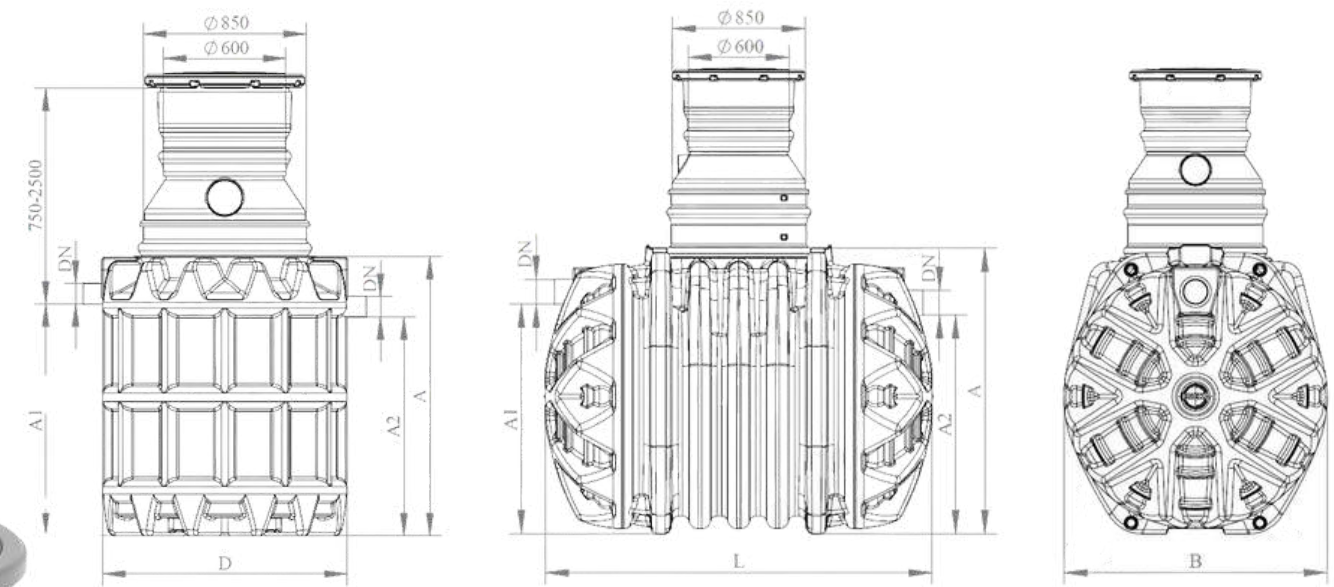
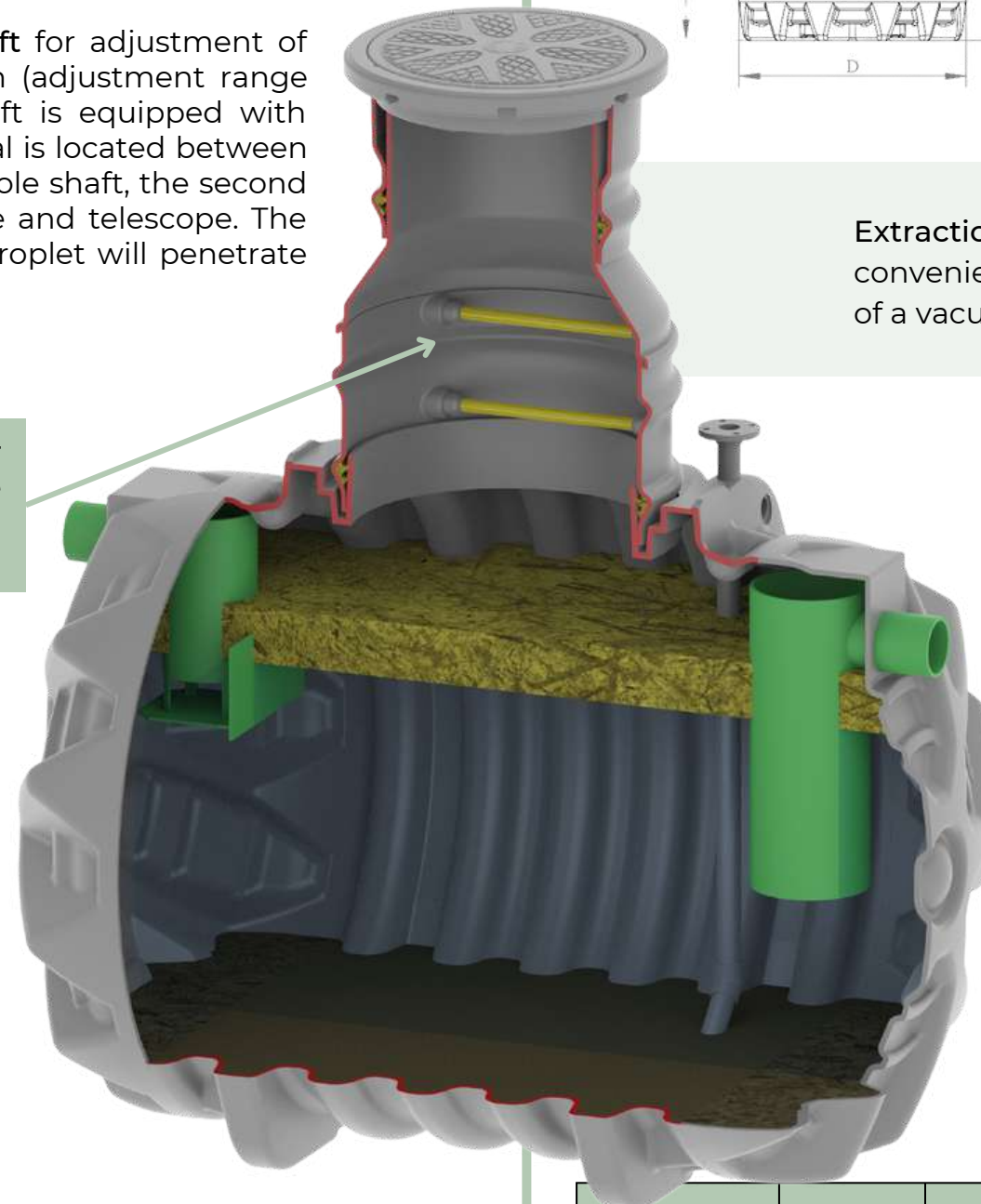

Extraction pipe can be paid to the area for convenient connection to extraction hose of a vacuum truck.



Easy transportation and installation

Greasily-B is made of polyethylene material therefore it is lightweight and easy to transport. Due to its rigid body, Greasily-B can be installed deep in the ground without any concrete reinforcements.

Lids

The maintenance shaft is designed for connection with standard polyethylene or cast iron lids for load classes from A15 to D400 according to standard EN 124. Polyethylene lid class A35 can be applied in the areas used by pedestrians, pedal cyclists and light vehicles on private household driveways (not part of the public highway).

Greasily - environmental friendly product

A very important feature of polyethylene products is that they can be easily recycled and reused thus reducing the waste and environmental impact.

Simple maintenance

GREASLY requires only little service which is limited by the removal of accumulated grease and sludge by a vacuum truck. After disposal, the internal surfaces of the separator shall be cleaned by the high-pressure device. Smooth surfaces of rotomoulded polyethylene tanks are ensuring simple and efficient cleaning.

| Type | Flow rate NS, l/s | Sludge trap volume, l | Separator volume, l | Grease volume, l | Total volume, l | Dimensions, mm | | | | | Weight, kg (without shaft) S/R ** | |
|--------------|-------------------|-----------------------|---------------------|------------------|-----------------|----------------|------|------|------|------|-----------------------------------|---------|
| | | | | | | D/L* | A | B | A1 | A2 | | DN |
| Greasily-1B | 1 | 100 | 250 | 40 | 350 | - | 1100 | 860 | 755 | 685 | 110 | 86/110 |
| Greasily-2B | 2 | 200 | 550 | 80 | 750 | - | 1000 | 1300 | 740 | 670 | 110 | 80/120 |
| Greasily-4B | 4 | 400 | 850 | 160 | 1250 | - | 1490 | 1300 | 1240 | 1170 | 110 | 96/146 |
| Greasily-7B | 7 | 710 | 1920 | 450 | 2620 | 2400 | 1510 | 1410 | 1170 | 1100 | 160 | 166/250 |
| Greasily-10B | 10 | 1030 | 2730 | 640 | 3760 | 2500 | 1830 | 1690 | 1170 | 1100 | 160 | 206/317 |
| Greasily-15B | 15 | 1560 | 3970 | 750 | 5530 | 3500 | 1830 | 1690 | 1450 | 1380 | 200 | 305/415 |
| Greasily-20B | 20 | 2140 | 4930 | 1000 | 7070 | 4500 | 1830 | 1690 | 1450 | 1380 | 200 | 376/535 |
| Greasily-25B | 25 | 2500 | 5720 | 1250 | 8220 | 5000 | 1830 | 1690 | 1450 | 1380 | 200 | 475/600 |

*L - for horizontal and D - vertical models

**S - Standard body for installation in depth ≤ 1500 mm, R - reinforced body for installation depth ≤ 2500 mm